



Summit Audio Inc.®

Summit Audio Model FeQ-50 Four-Band Parametric Passive Equalizer



Operation Manual

Summit Audio, Inc.
P.O. Box 326
Gardnerville, NV 89410
(775) 782-8838
email: sound@summitaudio.com

Introduction

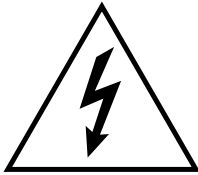

DANGER!
HIGH VOLTAGE

IMPORTANT: Check the bottom sticker to make sure the FeQ-50 is manufactured for the voltage used in your country. This is done at the factory or by a qualified service center only.

Introducing the FeQ-50 four band parametric, passive equalizer from Summit Audio. The focus of the FeQ-50 from the very beginning has been the sound. Passive circuitry excels at rich harmonic content and phase coherency, resulting in a musically satisfying sonic experience.

Each of the four bands has six switch selectable frequencies and 14dB of fully sweepable cut or boost. The low and high bands can switch between peaking and shelving filters, the low mid and high mid can switch between narrow and wide bandwidths. Also included is a switchable highpass filter fixed at 30Hz with a gentle 6dB/octave rolloff to reduce rumble. I/O includes a total of four simultaneous outputs, -10dB and +4dB vacuum tube out and -10dB and +4dB solid state out. Like all of our other half-rack sized products, the FeQ-50 has an internal power supply and 3 year warranty.

Features

- Fully passive design (no amplifier in filter circuit)
- Four frequency bands
- ± 14 dB cut and boost
- Six switch selectable frequencies per band
- Separate, bypassable high pass filter
- Master bypass
- Four simultaneous outputs, both vacuum tube and solid state
- Internal high voltage power supply
- One 12AX7A/ECC83 vacuum tube
- 3 year warranty
- Hand Crafted in the U.S.A.

Carefully unpack the FeQ-50 and it's power cord. Save the carton and packing material for possible future use. Before powering up the unit, read this manual and observe the cautions for **HIGH VOLTAGE**.

Important Warranty Information

For your 3 year warranty, register your FeQ-50 on line today at www.summitaudio.com.

Front Panel



Low Band

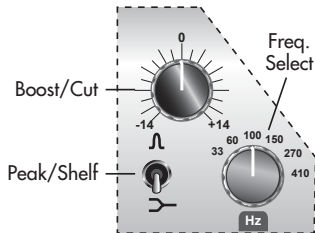

The Low EQ band can be set for either a peak or shelving response and can boost or cut by up to ± 14 dB. The center point of the filter band can be set to any of six frequencies: 33Hz, 60Hz, 100Hz, 150Hz, 270Hz, or 410 Hz.

Low-Mid Band

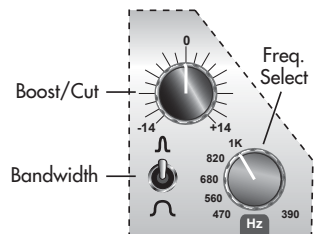

The Boost/Cut controls can boost or attenuate the chosen frequencies by up to ± 14 dB.

The Bandwidth (Q) is slightly less than 2 octaves in the narrow setting and slightly more than 3 octaves in the wide setting (maximum gain).

The center point of the filter band can be set to any of six frequencies: 390hz, 470Hz, 560Hz, 680Hz, 820Hz, or 1kHz.

High-Mid Band

The Boost/Cut controls can boost or attenuate the chosen frequencies by up to ± 14 dB.

The Bandwidth (Q) is slightly less than 2 octaves in the narrow setting and slightly more than 3 octaves in the wide setting (maximum gain).

The center point of the filter band can be set to any of six frequencies: 1.2 kHz, 1.5 kHz, 2.2 kHz, 3.3 kHz, 4.7 kHz and 5.6 kHz.

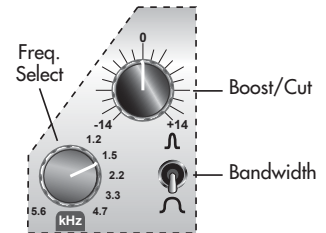

High Band

The High-Mid EQ band can be set for either a peak or shelving response and can boost or cut by up to ± 14 dB. The center point of the filter band can be set to any of six frequencies: 5 kHz, 7.2 kHz, 8.2 kHz, 10 kHz, 12.5 kHz, or 18kHz.

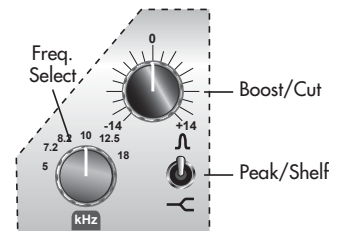

Bandwidth Control

On the two mid-bands, the bandwidth control sets the Q or width of the bell-shaped response curve. The bandwidth circuit employs a “proportional Q” design, which results in a wider bandwidth at low boost/cut settings and a narrow bandwidth at high boost/cut settings.

Peak or Shelving Response

The Low and High EQ bands can be set for either peak or shelving response. In shelf mode, for example, the High band continues to boost or cut frequencies above the center frequency. In peak mode the High band creates a bell-shaped response curve.

High Pass Filter

To reduce rumble or sub-audio frequencies, you have the option to enable this virtually transparent highpass filter. The frequency is fixed at 30Hz with a gentle 6dB/octave relief.

Bypass Switch

This switch bypasses all the passive EQ sections, but NOT the tube output stage which allows you to use the FeQ as a tube enhancement device to add warmth and natural sound to your digital recordings even when you don't need the EQ.

The FeQ-50 can also be used to convert -10dB (consumer) level signals into +4dB (professional) level.

Important - Please Read!

The FeQ-50 contains a vacuum tube which generates heat.

Do not block the cooling holes on the top of the FeQ-50 and always allow adequate ventilation when mounting the unit in a rack enclosure.

Rear Panel



A.C. Receptacle

The FeQ-50 is factory wired for either 100, 115 or 230 Volts AC. Before connecting AC power make sure the FeQ is wired for the voltage used in your country.

XLR Line Level / 1/4" Line Level Input

The Neutrik combination jack accepts either a balanced XLR or balanced 1/4" phone plug. The balanced XLR input is designed for +4dB line level input signals. The 1/4" input is designed to accept -10dB input levels only.

XLR Balanced Tube Output

This is a +4 dB balanced, low impedance XLR output connection compatible with professional recording and audio equipment. The tube output provides a warm, natural tube sound.

Note: You can use all four tube and solid state outputs at the same time for added versatility.

1/4" TRS Balanced Tube Output

This is a -10dB, balanced 1/4" output designed to interface with your recording device, compressor or EQ.

XLR Balanced Solid State Output

This is a +4dB, balanced, low impedance output connection compatible with professional recording and audio equipment. The Solid-State output provides a clean, low-noise signal.

1/4" TRS Balanced Solid State Output

This is a -10dB, balanced 1/4" output designed to interface with your recording device, compressor or EQ.

Basic Operation

Important: For proper operation of the FeQ-50 (or any vacuum tube device for that matter), allow the unit to warm up with power on for 15 minutes before use.

Important: Do not block the cooling holes and allow adequate ventilation.

Setting up a Parametric EQ

1. Turn up the gain on the band you are working with. This allows you to easily hear the effect of the filter.
2. Switch in the Narrow (N) bandwidth setting.
3. Adjust the Center Frequency to "zero-in" on the frequencies you wish to boost or cut.
4. Now that you've found the frequency you want, set the Gain to a more conservative value.
5. Widen the Bandwidth, if desired, to create a more natural sound.
6. Adjust the other bands as needed.

Applications

Dual-Output Mic/EQ Channel

The FeQ-50 in conjunction with the Summit Audio 2BA-221 provides you with a world-class mic preamp and passive EQ channel. As a bonus, you can record both the tube and solid-state outputs of the FeQ-50 on separate tracks.

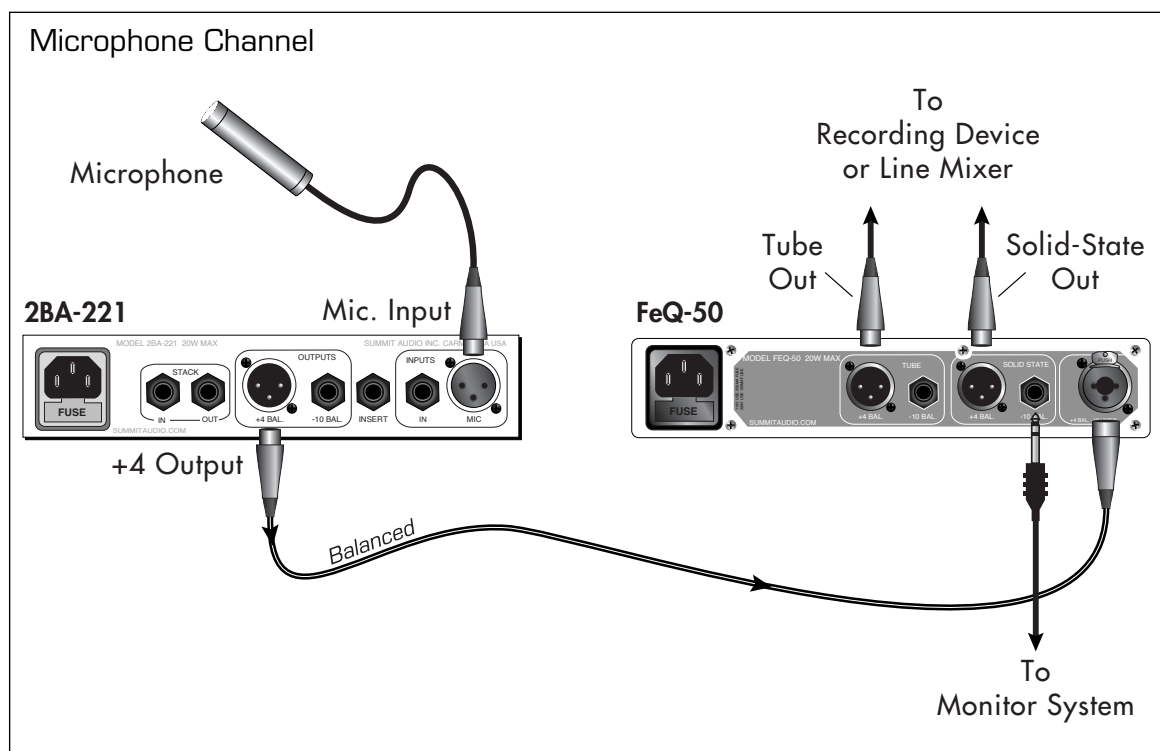

Mixer Insert

The Summit Audio FeQ-50 can be used to add world-class EQ to virtually any mixing board. The FeQ-50 should normally be interfaced using the insert point on your mixing board.

Most mixing boards contain a TRS (tip-ring-sleeve) insert point. A special TRS insert cable, as diagrammed below, makes this patch quick and easy.

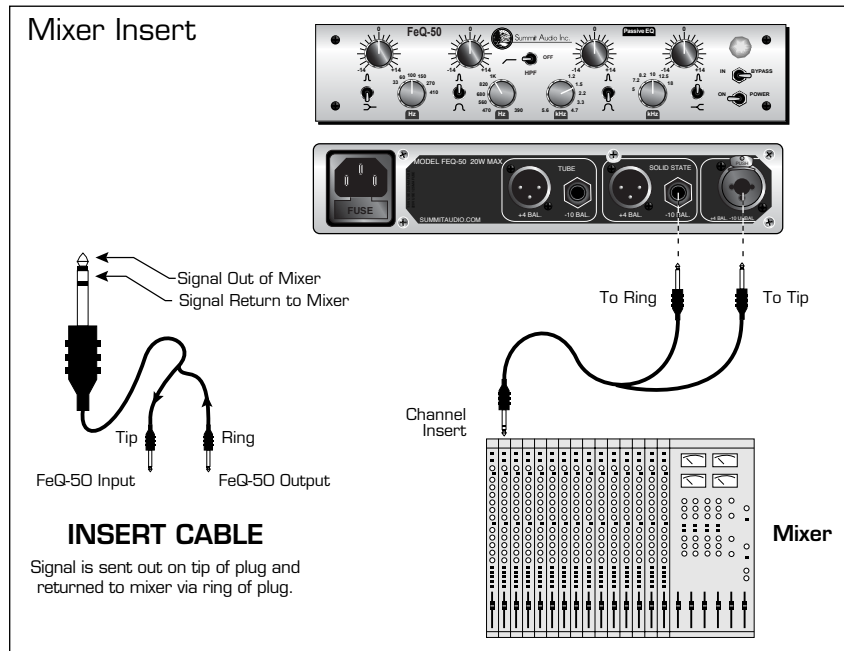

Note: Check the Insert level on your mixer. If your mixer uses a 0db to +4dB insert point, use the +4dB input and output on the FeQ-50 and an insert cable with XLR connectors.

Instrument Input Channel

For a great bass or guitar sound, add the Summit Audio TD-100 instrument preamp and tube direct box in conjunction with the FeQ-50.

Plug your instrument into the front panel of the TD-100 and run a balanced 1/4" cable from the output of the TD-100 to the input of the FeQ-50. Connect the 1/4" output of the FeQ-50 (either tube or solid-state) to the line in on your amp.

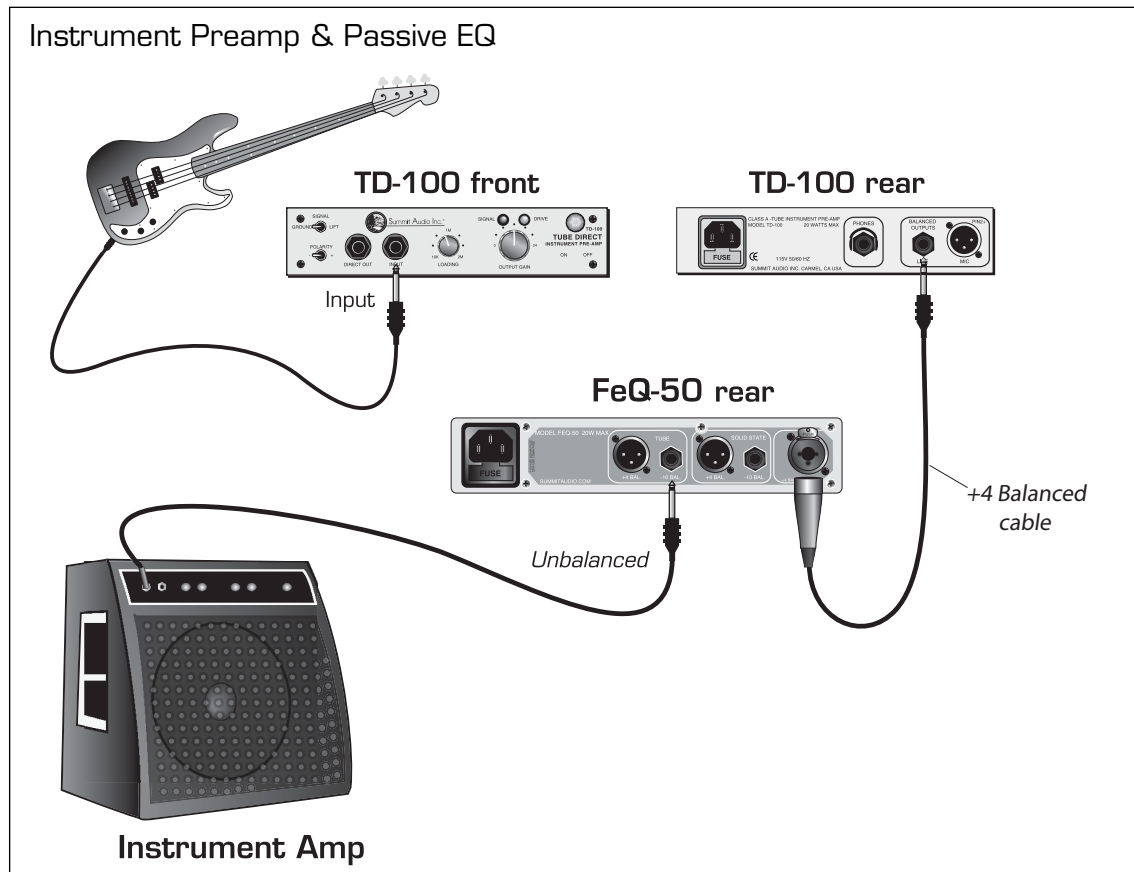

Ultimate Stereo Stage Setup

You can have the best of the tube and solid-state worlds with this stereo stage setup. Although two amps are needed, the two outputs of the FeQ-50 each impart a distinctive sonic signature which works beautifully to help provide the illusion of two players. The sound-sculpting possibilities are vast!

The Summit Audio TD-100 instrument preamp and tube direct box provides a line level signal for the FeQ-50. The balanced tube output of the FeQ-50 feeds a digital delay which drives the right side amplifier. The solid state output of the FeQ-50 goes directly to the left side amplifier.

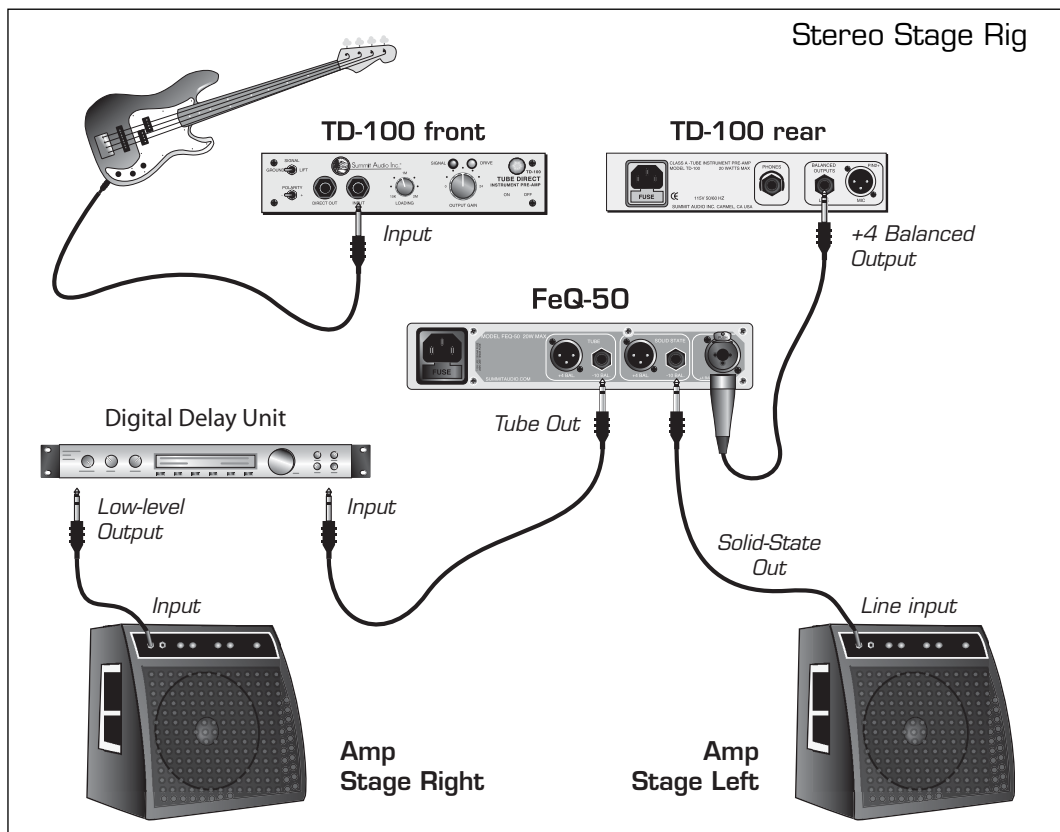

Block Diagram

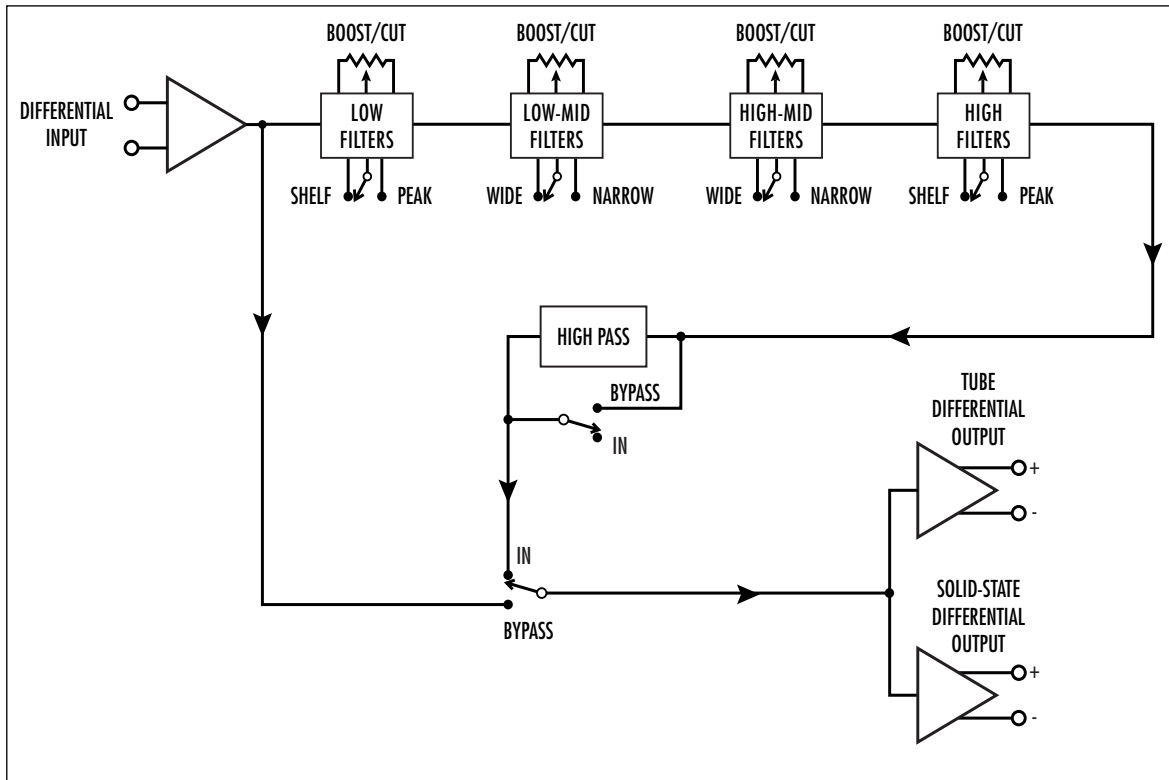

The electronically balanced input stage input goes directly into the passive EQ sections. The low and high bands can switch between peaking and shelving filters, the low mid and high mid can switch between narrow and wide bandwidths.

Also included is a switchable highpass filter fixed at 30Hz with a gentle 6dB/octave rolloff to reduce rumble. I/O includes a total of four simultaneous outputs, -10dB and +4dB vacuum tube out and -10dB and +4dB solid state out.

Electrical Connections

Input (Combination XLR line level / 1/4" line level jack)

Balanced 3-pin XLR (+4dB)

Pin 1 -- Ground
Pin 2 -- (+) Signal
Pin 3 -- (-) Signal

Balanced 1/4" Jack (-10dB)

Sleeve - Ground
Tip ---- (+) Signal
Ring --- (-) Signal

Solid State and Tube Outputs

Balanced 1/4" jack (-10dB)

Sleeve-- Ground
Tip ---- (+) Signal
Ring --- (-) Signal

Balanced 3-pin XLR (+4dB)

Pin 1 -- Ground
Pin 2 -- (+) Signal
Pin 3 -- (-) Signal

Specifications

Circuit Topology

Tube Output: High-voltage Class A
Solid-State Output: Class A/B

Power

Internal AC Supply
15 watts
115 volts
50 or 60 Hz
Fuse size is .5 amp, slo-blo for 100/115 V
Fuse size is .25 amp, slo-blo at 230 V

Dimensions

W: 8.5", **H:** 1.75", **D:** 8.5"
(Two units fit side by side on a standard one-space rack shelf. Order the SRK-100 Rack Kit from Summit Audio.)

Weight

7 pounds (3.15 kg)

Audio Specs

For current audio specifications please contact Summit Audio at www.summitaudio.com.



Summit Audio Inc.®

Summit Audio, Inc.

P.O. Box 326

Gardnerville, NV 89410

web page: www.summitaudio.com

email: sound@summitaudio.com

Please register on-line today at www.summitaudio.com.
Thanks.